

## Compliance

CE certificated post, compliant with standard UNI EN 40-5.



## Description

Modular post in UNI EN 1561 cast iron with core in S235J UNI EN 10219-1 steel, hot-galvanized to UNI EN ISO 1461 standards, corresponding in shape, size and ornamentation to the diagrams, which are an integral part of the specifications.

The core (A) is made up of four tubes of different cross-section, according to the internal diameter of the cast iron elements (diam. cm 13,3 x 100 - diam. 7.6 x 121 - diam. 6 x 70 - diam. 4.2 x 20), welded together at their junctions (B). The post is suitable for flange fixing (diam. cm 26,6 - thickness cm 1,8) on a foundation plinth (P). It is provided with an M10 earthing bolt, a slot (D - h. cm 18,6 x 4,5) for the installation of a class II insulation terminal board with or without fuse (Conchiglia) and at the top a 1 1/4" GAS thread (Z) used to secure with a bolt the various cast iron elements. The cast iron post is made up of a number of elements that are fitted over each other so as to prevent water infiltration. The elements are as follows:

- 1°) Base element height 96 cm, with a circular plinth (F, diam. 40 cm, height 10 cm) surmounted by a torus (G, diam. 40 cm) and a tapered central section 58.5 cm high (H - lower diam. 36 cm, I - top diam. 20 cm) with an inspection hatch (12 x 28 cm). The top of the element is composed of a band (L, diam. 29.5 cm) decorated with sixteen ovoli and surmounted by a scotia (M, diam. 15.5 cm) and a torus (N, diam. 22 cm).
- 2°) Second element height 106 cm, decorated at the base for a height of 26 cm with four leaves (O, diam. 21 cm). The upper part of the element is tapered (lower diam. 11.5 cm, top diam. 10.5 cm), and is decorated with sixteen flutes, a torus (Q, diam. 13.5 cm) and four rosettes (R).
- 3°) Third element height 105 cm, composed of a lower tapered section (lower diam. 10 cm, top diam. 9 cm) decorated with a torus at each end (S - diam. 13 cm, T - diam. 11.5 cm). The top section is in the form of a capital (lower diam. 10 cm, top diam. 23 cm) decorated with four leaves (U).

The above elements are all cast as single pieces.

The total height of these first three elements is 306 cm.

## Protection of surfaces

Please refer to the specification on painting procedures of the materials.

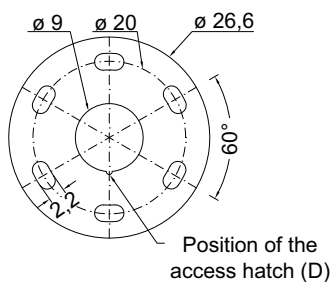

Flange plan  
Scale 1:10

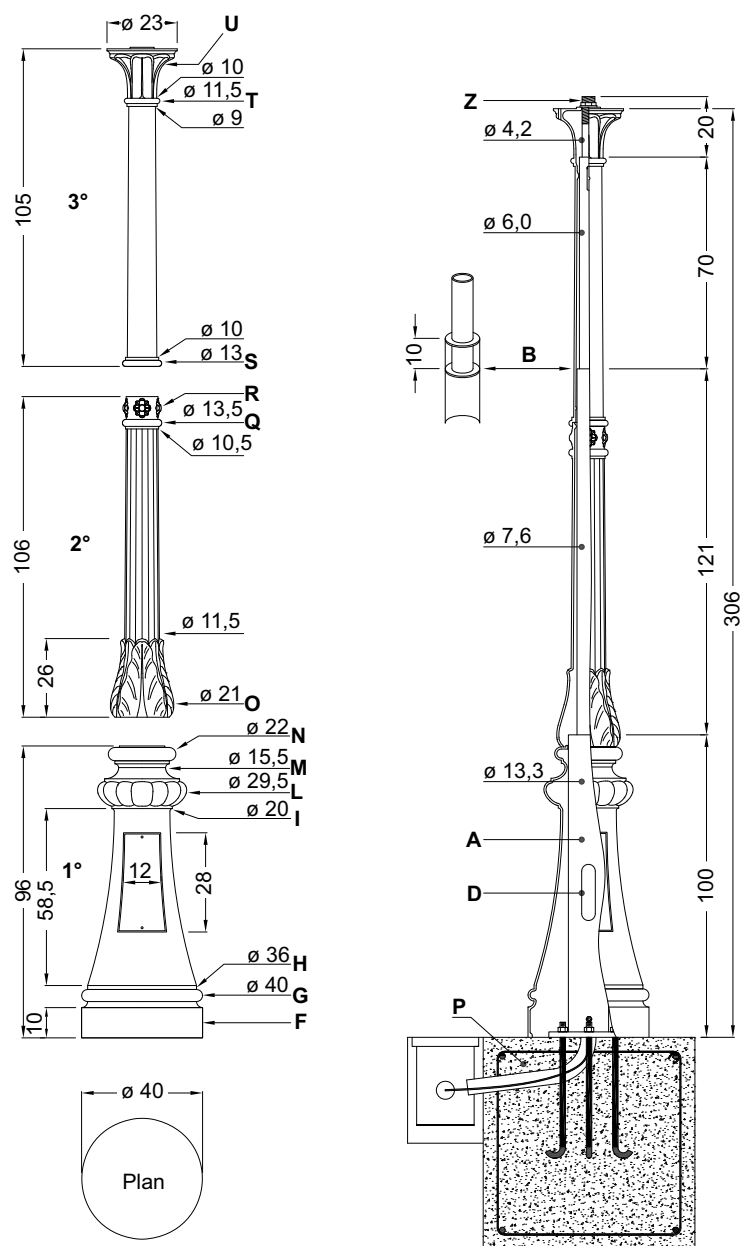

Exploded

Section

**NOTE:** The measurements are in centimetres.

**Neri S.p.A. Property** - Any reproduction and use for its own purposes is forbidden.